arm

An Era of Affordability for the Custom System- on-Chip (SoC)

Michele Riga, IoT/Embedded
Business, Arm

September, 2019

P2. Introduction

P2. Benefits of a custom SoC

P3. New products are driving down costs

P4. Accessible silicon technology

P5. Building-block IP availability and affordability

P6. Design help

P7. Case study: S3 Semiconductors and the oil and gas

industry P8. Silicon manufacturing options

P9. Beyond silicon: software reuse

P9. Conclusion



Now that electronic system design prototypes can be developed for under \$20,000, it pays to explore the benefits.

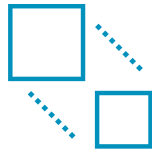
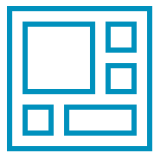

Introduction

The world is on track to design, make, and connect a trillion devices by 2035. It will be a diverse world of performance and use cases, but there are some universal design considerations: interoperability, security, scalability, resiliency, and in many cases, autonomy. There is no doubt that these considerations add complexity and warrant the need for custom silicon; however, there is also a need to shorten develop cycles and minimize costs. How can you have both?

Today, for reasons of cost efficiency and getting to market faster, most companies source secure, cost-efficient frameworks, services, and tools that accelerate development. These designs come from an expanding and reliable ecosystem of suppliers. Now, there are more hardware and software options for electronic system design than ever before, and this has meant that the cost of a custom SoC is increasingly affordable, and the benefits accessible, regardless of budget or expertise.

This white paper considers the benefits of building custom system-on-chip (SoC), and is supported by a study of an industrial control application with real-world data on cost, size, and power consumption.

Benefits of a Custom SoC

There are many potential reasons and benefits of building a custom SoC:

- ✦ Lowering overall product costs, replacing discrete components with one chip.
- ✦ Reducing component count, complexity, and PCB size.
- ✦ Improving reliability – a conventional PCB with hundreds of individual components has many potential failure points, many of which can be removed by limiting component count with custom silicon.
- ✦ Protecting the product, making it harder, or impossible, to reverse engineer and copy.
- ✦ Reducing supply chain complexity and assuming complete ownership of the chip, ensuring long life supply using established foundries and process nodes.
- ✦ Making a product more compelling and differentiated by adding new features not available in standard products.
- ✦ Meeting performance and/or cost requirements for a specific application or product that are impossible to reach with a PCB approach.

Years of device supply can be maintained at lower cost.

Supply chain security is a crucially important factor. Completed silicon wafers, without the cost of testing and packaging, can be stored securely and then accessed over time. Years of device supply can then be maintained at lower cost. This contrasts with maintaining a supply of many discrete components that must be purchased at full price in advance. The benefits of custom silicon for the purchasing and supply chain team are substantial.

What's more, thanks to the availability of proven IP, skilled design service companies, and mature chip manufacturing, designing a custom SoC no longer requires a huge investment. Prototype test chips can be manufactured for under \$20,000, a figure that most OEMs can easily afford.

New Products are Driving Down Costs

The last few decades have been marked by significant growth in the quantity of digital devices shipped. The graph below shows the growth in the number of chips shipped by Arm's partners in the last 20 years.

Completely new classes of products have been created, such as the first mobile phones, smartphones, and wearables. At the same time, existing products have evolved, with vehicles, white goods, and industrial equipment all becoming increasingly digital.

Most low to medium-volume products are built from off-the-shelf semiconductor components. However, this approach often limits performance, power efficiency and cost-competitiveness, especially when many of the analog and digital components have to meet product requirements. Using custom SoCs can overcome these hurdles.

Figure 1: Number of Arm-based chips shipped in the last 20 years.

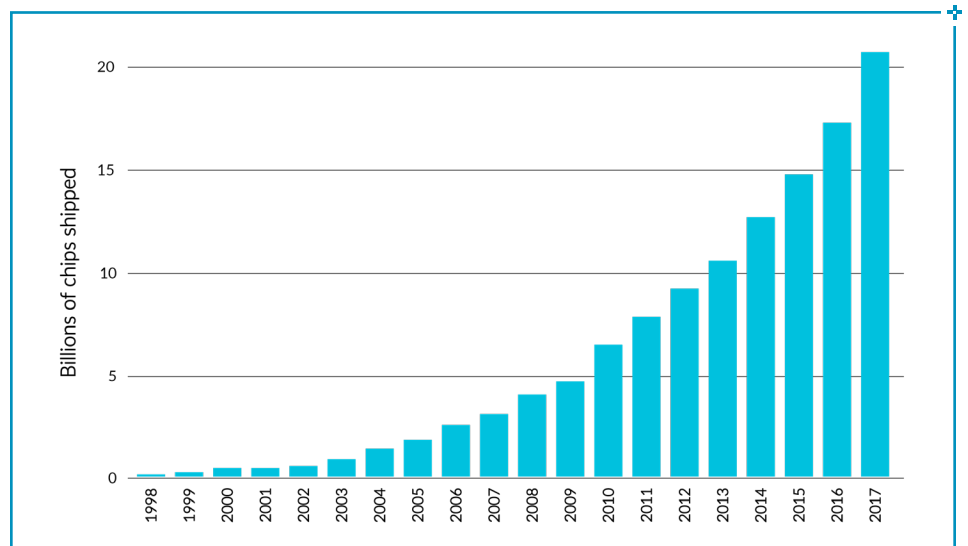

Accessible Silicon Technology

Innovation also has accelerated on mature technology.

Moore's Law refers to the doubling of transistor count on a given silicon area approximately every two years. The latest 7nm technologies are marvels of extreme miniaturization, driving the digital revolution in smartphones, servers, TVs and network infrastructure.

However, important improvements in older (but still advanced semiconductor nodes are often forgotten. The costs of designing at these mature nodes is a fraction of what it used to be. At the same time, the available technologies for low-leakage, low-power, or high-voltage design have all multiplied. Innovation has not stopped on mature technology – it has accelerated.

These mature nodes can also be used for applications where added value is provided by incorporating circuit elements that don't necessarily scale according to Moore's Law, such as sensors and actuators. This is referred to as "More than Moore".

Figure 2: More than Moore diagram

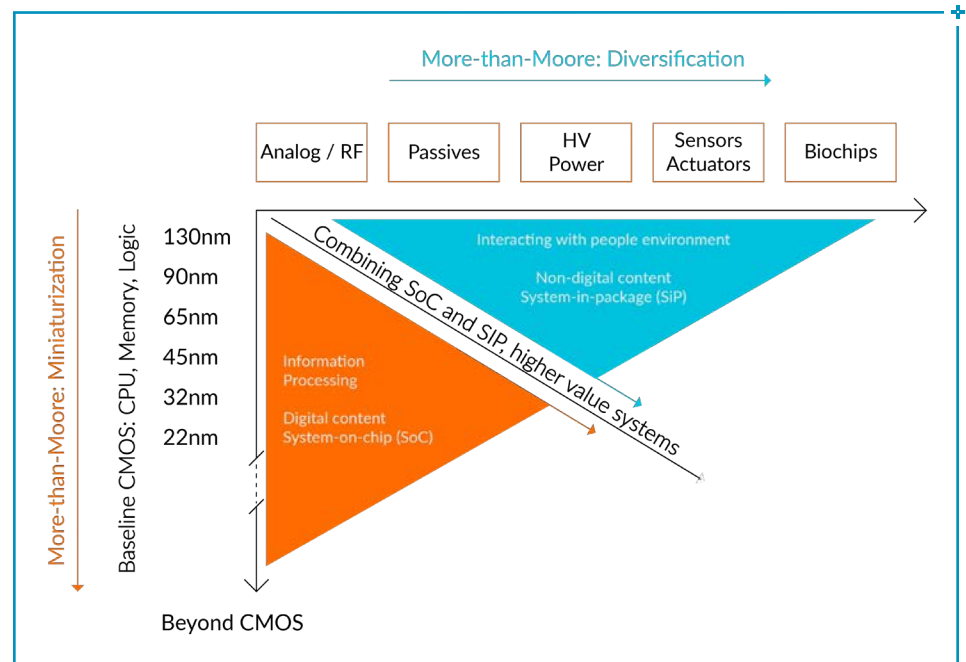

Courtesy of the "More-than-Moore" white paper, International Technology Roadmap for Semiconductors (ITRS), 2011, by W. Arden, M. Brillouet, P. Copez, M. Graef, B. Huizing, R. Mahnkopf.

Today, a prototype chip can be built on a 180nm process for only \$18,000. Even using a node that once powered early smartphones, 65nm, the cost is now just \$48,000. Wafer fabs are fully depreciated, with yields at very high levels.

The availability of mature process nodes to realize a custom SoC that pulls together mixed-signal devices, microcontrollers, input and output, drivers, power management, and so on, is wider than ever before.

Figure 3: Process node costs for 180nm, 130nm, and 65nm have declined steadily over time (courtesy of imec ic-link).

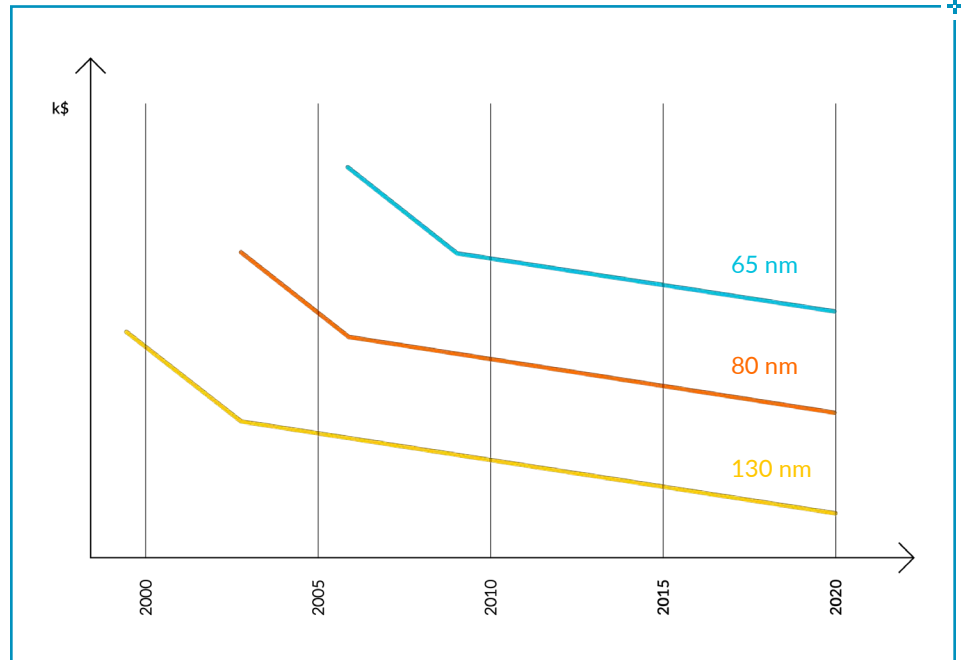

Building-block IP Availability and Affordability

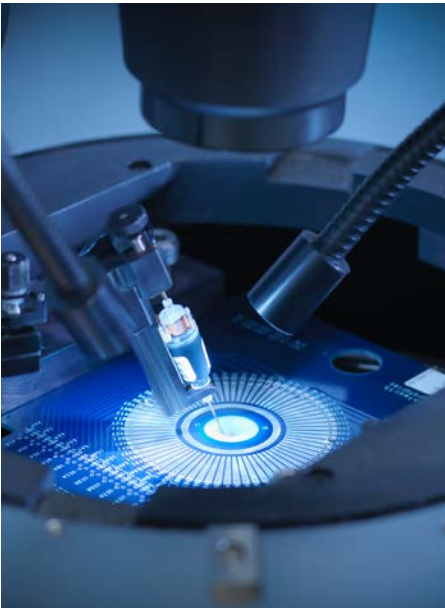

When building a chip, all the required components can be easily purchased from third-party vendors or may be provided by a design services partner from its own portfolio.

Arm Cortex processor IP is found in billions of off-the-shelf devices. Through licensing programs such as Arm DesignStart and Arm Flexible Access, OEMs can get the help they need building custom SoCs.

DesignStart provides fast access to the Cortex-M0 and Cortex-M3 processors through a simple contract, with no upfront fee, just a success-based royalty model. DesignStart packages also provide a subsystem and a range of IP blocks and peripherals to build or to customize. The subsystems contain all the common elements needed as a starting point, or simply as a reference design.

The Cortex-M3 DesignStart package contains:

- ✦ Cortex-M3 processor and a configurable memory system
- ✦ Ready-made connectivity to Flash memory with an integrated Flash cache
- ✦ Connectivity to peripherals
- ✦ Real-time clock
- ✦ True Random Number Generator (TRNG) to provide the foundation for security
- ✦ Dedicated port for integration with the Arm Cordio radios

Alternatively, Flexible Access provides access to a wider range of IP products, support, tools and training for unlimited design time and with payment due only at the point of manufacture. The licensing model includes a wide range of Cortex-A, Cortex-R and Cortex-M CPUs, Mali GPUs, Corstone foundation IP package, System IP, Security IP and Artisan physical IP libraries.

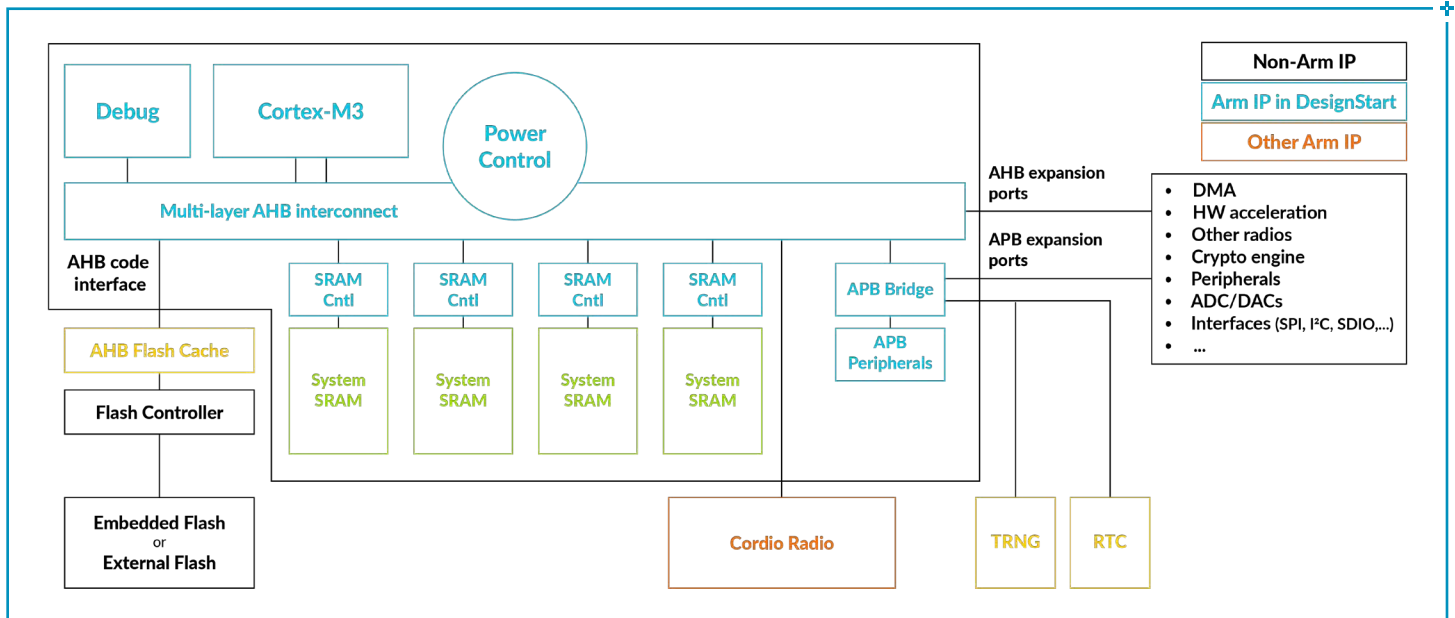

Figure 4: SSE-050 subsystem block diagram

Design Help

Development can be easily outsourced to reputable design service companies. These companies can assist in all phases of the custom SoC process, enabling OEMs to outsource any part of the project, from definition to design, integration, verification, and manufacturing. Some of them can provide a complete turnkey service, delivering a microchip ready to be used.

The Internet of Things (IoT) adds new dimensions to the custom SoC world, as there are now OEMs and companies looking to create custom silicon with no previous experience. To help, Arm has established the Approved Design partner program. This program connects companies with audited design partners, chosen for the quality of the services that they can provide and with a proven track record of successfully using Arm IP.

Case Study: S3 Semiconductors and the Oil Gas Industry

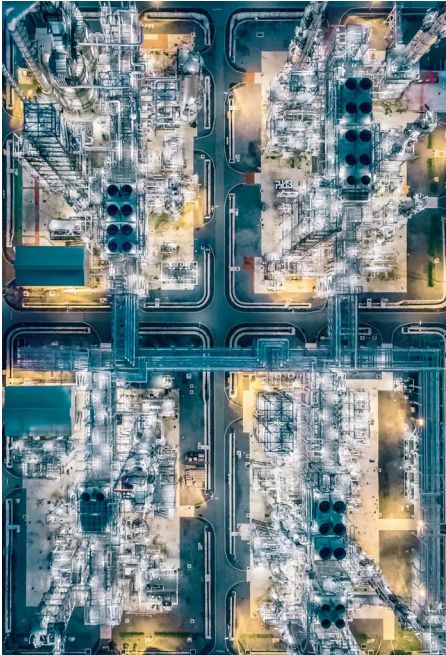

Semiconductor design and manufacturing company, S3 Semiconductors, recently developed a custom SoC for a company in the oil and gas industry. The customer makes complex valve controllers that sense pressure and temperature. The original controller design was based on a PCB containing a large variety of off-the-shelf digital and analog parts.

For its next generation product, the customer decided to replace all of its off-the-shelf parts with one integrated solution. Their motivation was to reduce costs, improve reliability, and simplify the inventory and supply management. Supply management, in particular, was a major concern as some of the customer's vendors were planning to discontinue components that had been used in the original design. In addition, the company wanted to add customized functionality with new connectivity to remotely manage valves in the field. Like most OEMs, the company had no in-house silicon design expertise so they decided to outsource the project to S3 Semiconductors.

S3 Semiconductors developed a low-power chip based on the 180 nm process node, integrating digital-to-analog and analog-to-digital converters (DAC and ADC), and communication interfaces that included I2C, UART, and SPI, all in a low-power design consuming 160 uW/MHz. The results of the project were:



80%

reduction in
bill-of-materials cost.



70%

reduction in
power consumption.

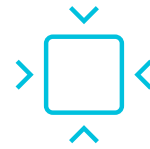

75%

reduction in
PCB size.

Silicon Manufacturing Options

Manufacturing options for prototypes and production chips include:

- + Multi-project wafer (MPW): combining projects from different customers to amortize costs. It can be used for early prototypes, or for full production when a very low volume is required.
- + Multi-layer mask (MLM): combining various masks into one, reducing the cost of the mask set. However, the production cost (wafer cost) increases since more foundry production time is required for production.
- + Full mask-set: OEMs provide their own set of masks for full production. Ideal for medium to large volume projects.

Almost every custom ASIC project starts with a prototype through an MPW. For low-volume production, or mid-volume ones with small die size, MPWs and MLMs are cost-effective. Almost every foundry provides accessible and frequent MPWs or MLMs services, for the various technology nodes.

Clearly, the realization of custom SoCs is now cost-effective and affordable for small companies or low-volume projects. An analysis performed by imec IC-link, the semiconductor manufacturing division of imec's R&D and innovation hub, shows how at 180 nm, production of only a few thousand units makes financial sense, before you consider the multiple additional benefits of custom SoCs.

Figure 5: Custom SoCs can be profitable at low volume.

Minimum number of units required for an investment in custom SoC. On 180 nm, with current technology costs, a few thousand units per year are a minimum requirement (courtesy of imec, IC-link).

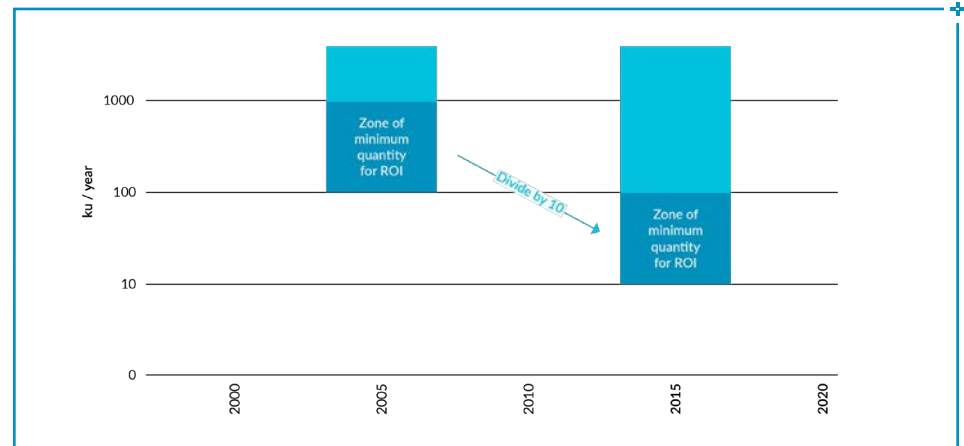

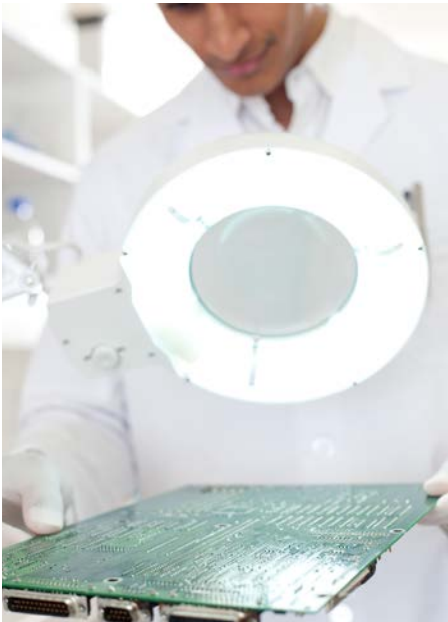

Beyond Silicon: Software Reuse

Assembling a chip and manufacturing it is not the end of a custom SoC project. Hardware has little value unless it's paired with software that is optimized to run and take full advantage of all the hardware functions implemented. If software engineers are worried about the move to a custom part, they can be reassured that developing, debugging and reusing software remains the same as today. In fact, the same extensive software and tools ecosystem that enables software developers to easily build software for off-the-shelf Arm-based MCUs can also be leveraged when transferring to Arm-based custom SoCs.

In addition, companies are using legacy 8 or 16-bit MCUs, then life for software developers is about to get even better. OEMs using off-the-shelf MCUs or CPUs will find that moving to a custom SoC, reusing existing software investments and sharing new code with future projects is far more straightforward than expected.

Conclusion

The barrier to developing chips has dropped significantly and this has led to an explosion in the number of custom SoCs powering IoT and embedded applications across a wide range of industries

OEMs should consider how a custom SoC can work for them. There is an abundance of IP available, from proven microprocessors to peripherals and accelerators. Processors, subsystem IP, tools and models can be accessed in a number of ways, depending on your needs:

- Arm DesignStart provides access to a select mix of IP products and tools with a low upfront license fee.
- Arm Flexible Access gives SoC design teams access to a wide range of IP products, support, tools and training for unlimited design time and with payment due only at the point of manufacture.

These access models provide SoC designers with unlimited flexibility to experiment, evaluate and design, and ensures overall costs remain proportional to the size of the project.

[Start your custom SoC today by exploring the options available for accessing IP with Arm.](#)